

**SWR AUTOTESTERS AND BRIDGES
OPERATION AND MAINTENANCE
MANUAL**

WILTRON

**SWR AUTOTESTERS AND BRIDGES
OPERATION AND MAINTENANCE
MANUAL**

WILTRON

490 JARVIS DRIVE • MORGAN HILL, CA 95037-2809
TEL. (408) 778-2000 • TELEX 285227 WILTRON MH • FAX 408-778-0239

P/N: 10100-00008
REVISION: J
PRINTED: SEPTEMBER 1988
COPYRIGHT 1983 WILTRON COMPANY

WARRANTY

All products are warranted against defects in materials and workmanship for one year from the date of shipment except YIG-tuned oscillators, which have a two-year warranty period. Our obligation covers repairing or replacing products which prove to be defective during the warranty period and which shall be returned with transportation charges prepaid to WILTRON. Obligation is limited to the original purchaser. We are not liable for consequential damages.

7-58-60/62-64/67/87/97-OMM

IMPORTANT

Dear Customer:

To better serve you, WILTRON Company is now mailing change pages directly to our manual holders.

To receive future change pages, remove this page from your manual, fill out, detach, and return the self-addressed card below (no postage necessary, when mailed in the United States).

Thank You,
WILTRON Company

Tear Here

Mail TODAY;
no postage
required in
U.S.A.



- I *recommend* purchase of equipment/instruments.
- I *authorize* purchase of equipment/instruments.

The following were influential in my choice of WILTRON products:

- Magazine advertisements
- Direct mailings
- Personal recommendation
- Visit from sales rep.
- Other _____

P/N: 00986-00001
REV: D

MR-1084

MANUAL REGISTER

Fill in manual number and Rev. :

P/N 10100-00008, REV. J

(Manual number is located in the lower right corner of title page.)

Please print.

Name _____

Title _____

Company _____

Address _____

City _____

State _____ Zip _____

Country _____

Phone _____ Ext. _____



No
Postage Stamp
Necessary
If Mailed in the
United States

BUSINESS REPLY MAIL
First Class Permit No. 2, Morgan Hill, CA



WILTRON Company
490 Jarvis Drive
Morgan Hill, CA 95037-2809
USA

TABLE OF CONTENTS

<u>Section</u>		<u>Page</u>
I	GENERAL INFORMATION	
	1-1. Introduction	1-1
	1-2. General Description	1-1
	1-3. Explanation of SWR Autotester and Bridge Specifications	1-1
	1-4. Precautions	1-1
	1-5. SWR Autotesters, Specifications	1-5
	1-6. SWR Bridges, Specifications	1-5
II	THEORY OF OPERATION	
	2-1. Introduction	2-1
	2-2. Description	2-1
III	MAINTENANCE	
	3-1. Introduction	3-1
	3-2. Recommended Test Equipment	3-1
	3-3. Directivity Measurements	3-1
	3-4. Pin Depth Measurements	3-2
	3-5. Maintenance	3-3
	3-5.1 Adjustments	3-3
	3-5.2 Cleaning	3-3

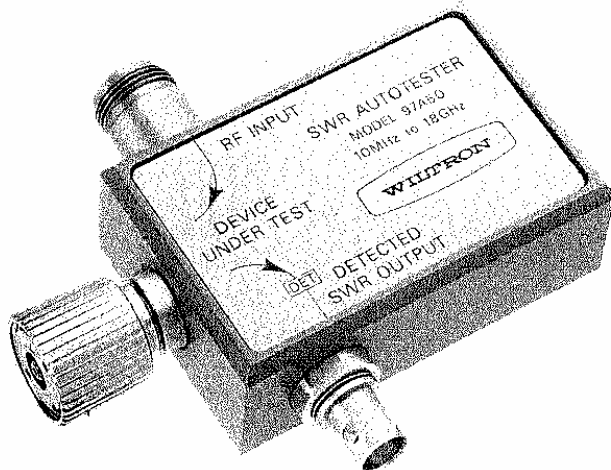
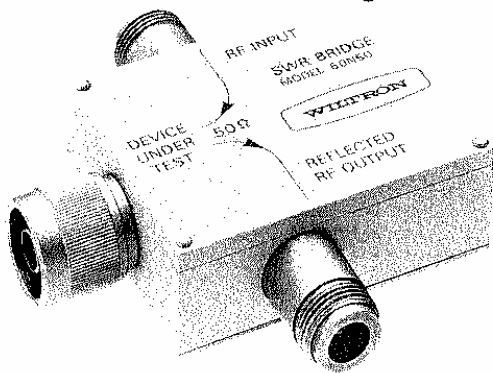

Figure 1-1. Model 60N50 SWR Bridge and 97A50 SWR Autotester

SECTION I

GENERAL INFORMATION

1-1 INTRODUCTION

This manual provides specifications, description, and procedures for measuring the directivity of WILTRON Series 59, 63, 67, and 97 SWR Autotesters and the Series 58, 60, 62, 64, and 87 SWR Bridges. See the Table of Contents for the manual organization.

1-2 GENERAL DESCRIPTION

The SWR Autotesters and bridges (Figure 1-1) described in this manual are broadband microwave measurement instruments. They are used with other test instruments for making fixed- and swept-frequency return loss (SWR) measurements over a wide range of radio frequencies. Return loss measurements are made to check the performance of systems, subsystems, and microwave components such as amplifiers, directional couplers, attenuators, filters, splitters, and terminations.

The WILTRON SWR Autotesters and bridges offer significant advantages over other microwave measurement devices such as slotted lines and dual-directional couplers. Advantages include using an unmodulated microwave source and providing a greater degree of accuracy over a broader frequency range for both direct and comparison-type measurements.

The WILTRON SWR Autotesters and bridges are precision-balanced Wheatstone bridges. Except for the two 4-port comparison-type instruments (Models 59A50 and 58A50) that use an offset termination in the reference arm, every model has an internal precision reference termination included in one arm of its bridge. The only difference between the SWR Autotester and the SWR bridge is that the SWR Autotester contains a built-in RF detector. Because the SWR bridge does not contain a built-in detector, however, it offers a greater degree of flexibility in low-level signal measurements where additional RF

amplification is required. Also, the undetected RF output of the bridge can be applied directly to the detectors of a network analyzer or other RF signal-processing equipment where phase information is needed.

1-3 EXPLANATION OF SWR AUTOTESTER AND BRIDGE SPECIFICATIONS

Certain key terms used to specify characteristics of the SWR Autotesters and bridges are explained below.

- a. Accuracy. This term defines the accuracy with which an SWR Autotester or bridge can make a reflected signal measurement. Refer to Figure 1-2 for a description of the term.
- b. Directivity. A figure of merit expressed in dB. This figure represents the ratio of the power levels as seen at the output port under the following two conditions:
 - (1) When the test port signal is fully reflected, and
 - (2) When the test port is perfectly terminated.
- c. Frequency Sensitivity. The maximum variation in output power/voltage that can be expected due to a change in frequency over the specified range when the input power is held constant.
- d. Output Time Constant. The amount of time required for the selected output pulse to either rise from the 10% to the 90% point or fall from the 90% to the 10% point on the waveform.

1-4 PRECAUTIONS

The WILTRON SWR Bridges and SWR Autotesters are high-quality, precision, laboratory instruments that should receive the same

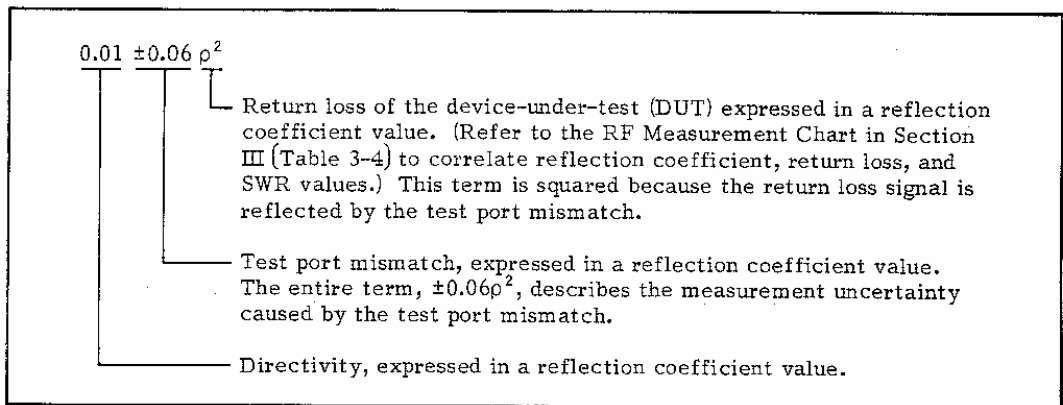

Figure 1-2. Description of the Accuracy Term, As Applied to SWR Autotesters and Bridges

care and respect afforded other such instruments. Complying with the following precautionary notes will guarantee longer component life and less equipment downtime due to connector or component failure. Also, such compliance will ensure that bridge and SWR Autotester failures are not due to misuse or abuse, two failure causes not covered under the WILTRON warranty.

- a. Beware of Destructive Pin Depths on Mating Connectors.¹ Measure the pin depth (Figure 1-3) of the test device connector before mating it with the bridge or SWR Autotester test port connector. Based on bridges and SWR Autotesters returned for repair, destructive pin depths on mating connectors are the chief cause of failure in the field. When any bridge or SWR Autotester connector — especially the test port connector — is mated with a connector having a destructive pin depth, the bridge or SWR Autotester connector will probably be damaged. (A destructive pin depth has a center pin that is too "long" in respect to the connector's reference plane.)

The center pin on all of the bridge and SWR Autotester connectors has a preci-

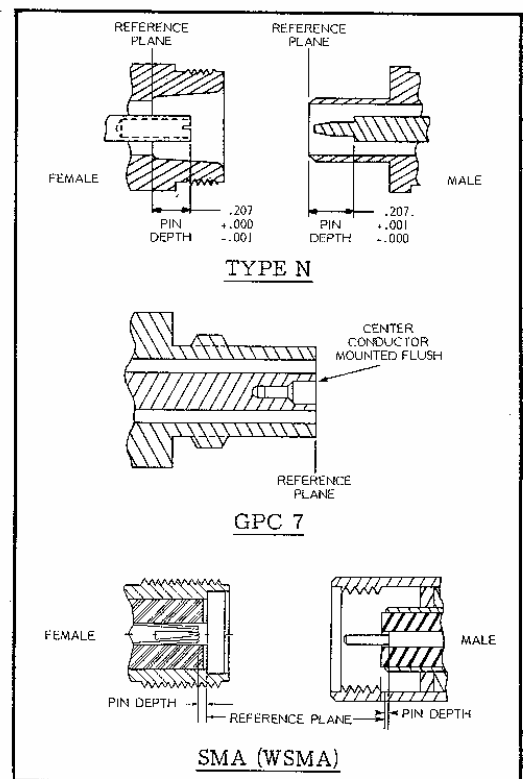

Figure 1-3. Connector Pin Depth

¹The term "pin" is used in a generic sense. It refers to both the center conductor pins on type N and SMA (WSMA) male connectors and the center conductor sleeves on type N, GPC 7, and SMA (WSMA) female connectors.

sion tolerance measured in mils (1/1000 inch). However, connectors on test devices that mate with the bridge and SWR Autotester test port connector, may not have the proper pin depth. They must be measured before mating to ensure suitability. Gauging sets for measuring pin depth are available (Section III).

When gauging pin depth, if the test device connector measures out of tolerance (Table 1-1) in the "+" region (Figure 1-4) the center pin is too long. Mating under this condition will probably damage the bridge or SWR Autotester connector. On the other hand, if the test device connector measures out of tolerance in the "-" region, the center pin is too short. A mating, while not causing any damage, will result in a poor connection and will degrade the quality of the measurement.

- b. Avoid Over-Torquing Connectors. Applying too much torque to the connectors that mate with bridges and SWR Autotesters is another cause of premature failure. Such over-torquing is destructive, because it may damage the connector center pin or may cause the connector body to turn in its housing. Finger-tight is usually sufficient, especially on type N and GPC 7 connectors. Should it be necessary to use a wrench to tighten SMA

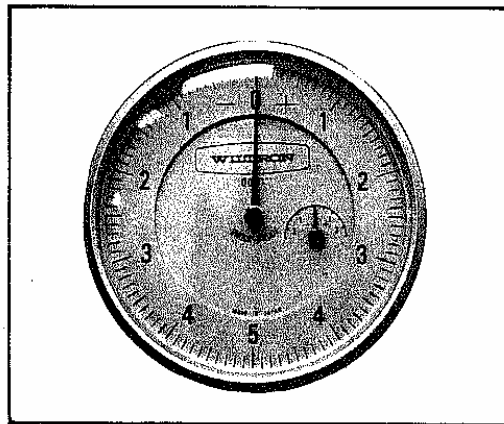

Figure 1-4. Pin-Depth Gauge

Table 1-1. Pin Depth Tolerances for SWR Bridges and SWR Autotesters

SERIES	PORT/CONNECTOR TYPE	PIN DEPTH (Mils)	MMC GAUGE READING ¹
58, 64, 65, 66, 69, 87, 97 ²	INPUT-NF	207 +0.000 -0.010	Same as Pin Depth
	OUTPUT-NF	207 +0.000 -0.010	
58, 59, 69, 87, 97	TEST-A	+0.000 -0.003	210 -0.003 -0.001
97	TEST-N	207 -0.000 +0.002	
97	TEST-NF	207 +0.000 -0.002	Same as Pin Depth
	TEST-S ³	-0.0025 -0.0035	
	TEST-SF ³	-0.0003 -0.0007	
60, 63	INPUT-NF	207 +0.000 -0.020	210 -0.003 +0.000
60	OUTPUT-NF	207 +0.000 -0.020	
60, 63	TEST-A	+0.000 -0.003	Same as Pin Depth
	TEST-N	207 +0.000 +0.003	
62, 67	TEST-NF	207 +0.000 -0.003	Same as Pin Depth
	INPUT-NF	207 +0.000 -0.020	
62	OUTPUT-NF	207 +0.000 -0.020	210 -0.003 +0.015
62, 67	TEST-N	207 -0.000 +0.018	
62, 67	TEST-NF	207 +0.000 -0.010	Same as Pin Depth

LEGEND AND NOTES

Typical Model Number:

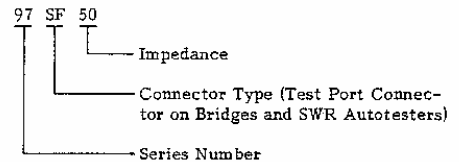

Connector-Type Abbreviations:

- N = Type N male
- NF = Type N female
- A = GPC7
- S = WSMA male
- SF = WSMA female

¹MMC is Maury Microwave Corp.

²No output connector on 97 series SWR Autotesters.

³SMA connectors that mate with WSMA connectors should have the same pin depth tolerance.

or WSMA connectors, however, use a torque wrench that breaks at 5 inch-pounds. As a general rule, NEVER USE PLIERS TO TIGHTEN CONNECTORS.

- c. Avoid Applying Excessive Power. All of the bridges and SWR Autotesters described have a maximum input power rating of 0.5 watts (+27 dBm). Applying power levels beyond this value, for even short durations, can seriously damage the instrument's internal components.
- d. Do Not Disturb Teflon Tuning Washers on Connector Center Pins. The center conductor on most bridge and SWR Autotester test port connectors contains a small teflon tuning washer located near the point of mating (interface). This washer (Figure 1-5) compensates for minor impedance discontinuities at the interface. The washer's location is critical to the bridge or SWR Autotester performance, DO NOT DISTURB.

When making field repairs of WSMA test port connectors, however, discard the washer. Although discarding this washer may degrade the original return loss specification by 3 to 4 dB, the return loss will be better than if the washer is incorrectly placed. If the degradation to return loss is unacceptable, the bridge or SWR Autotester should be returned to WILTRON for alignment.

- e. Avoid Mechanical Shock. WILTRON bridges and SWR Autotesters are designed to withstand years of normal bench handling. However, do not drop or otherwise roughly handle them. They are laboratory-quality instruments. All bridges and SWR Autotesters are shipped from the factory in sturdy, wooden boxes containing form-filled, foam-rubber padding. These boxes should be used to store the component when it is not in use.
- f. Keep Component Connectors Clean. The precise geometry that makes possible the

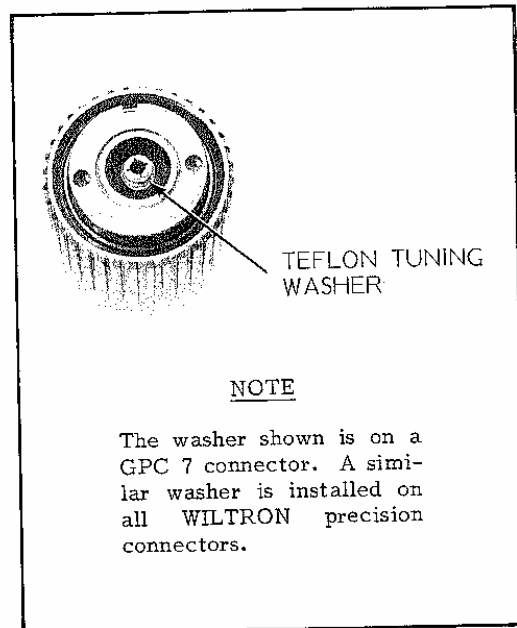

Figure 1-5. Teflon Tuning Washer on GPC 7 Connector

bridge's and SWR Autotester's high performance can be easily disturbed by dirt and other contamination adhering to connector interfaces. When not in use, keep the component connectors covered. Refer to paragraph 3-5.2 for cleaning instructions.

1-5 SWR AUTOTESTERS, SPECIFICATIONS

Table 1-2 provides specifications for the 59, 63, 67 and 97 series SWR Autotester.

1-6 SWR BRIDGES, SPECIFICATIONS

Table 1-3 provides specifications for the 58, 60, 62, 64 and 87 series SWR Bridges.

Table 1-2. SWR Autotesters, Specifications

MODELS	FREQUENCY RANGE	DIR (dB)	ACCURACY ②	INPUT Z (ohms)	TEST PORT CONNECTOR TYPE	PHYSICAL
Series 63 SWR Autotesters						
63N50 63NF50 63A50	10 to 4000 MHz	40 ①	$0.01 \pm 0.06\rho^2$	50	Type N Male Type N Female GPC-7	Dimensions: 6.7 x 5.1 x 2.54 cm (2-5/8 x 2 x 1 inches) excluding connectors Weight: 340 grams (12 ounces)
Series 67 SWR Autotesters						
67N50 67NF50 67B50 67BF50 67N75 67NF75 67B75 67BF75 67FF75	10 to 1000 MHz	40	$0.01 \pm 0.1\rho^2$	50 50 50 50 75 75 75 75 75	Type N Male Type N Female BNC Male BNC Female Type N Male ③ Type N Female ③ BNC Male BNC Female Type F Female	Dimensions: 6.7 x 5.1 x 2.54 cm (2-5/8 x 2 x 1 inches) excluding connectors Weight: 170 grams (6 ounces)
Series 59 Comparison SWR Autotester						
59A50	10 MHz to 18 GHz	36	$\frac{10 \text{ MHz to } 8 \text{ GHz}}{0.016 \pm 0.06\rho^2}$ ④ $\frac{8 \text{ GHz to } 18 \text{ GHz}}{0.016 \pm 0.1\rho^2}$ ④	50	GPC-7 on Test and Reference Ports	Dimensions: 7.6 x 5 x 2.8 cm (3 x 2 x 1-1/8 inches) excluding connectors Weight: 340 grams (12 ounces)
Series 97 SWR Autotesters						
97A50 97A50-1 97S50 97SF50 97S50-1 97SF50-1 97N50 97NF50 97N50-1 97NF50-1	10 MHz to 18 GHz	36 40 35 38 35 38	$\frac{10 \text{ MHz to } 8 \text{ GHz}}{0.016 \pm 0.06\rho^2}$ $\frac{8 \text{ GHz to } 18 \text{ GHz}}{0.016 \pm 0.1\rho^2}$ $0.01 \pm 0.06\rho^2$ $0.01 \pm 0.1\rho^2$ $0.018 \pm 0.08\rho^2$ $0.018 \pm 0.12\rho^2$ $0.013 \pm 0.08\rho^2$ $0.013 \pm 0.12\rho^2$ $0.018 \pm 0.08\rho^2$ $0.018 \pm 0.12\rho^2$ $0.013 \pm 0.08\rho^2$ $0.013 \pm 0.12\rho^2$	50	GPC-7 GPC-7 WSMA Male WSMA Female WSMA Male WSMA Female Type N Male Type N Female Type N Male Type N Female	Dimensions: 7.6 x 5 x 2.8 cm (3 x 2 x 1-1/8 inches) excluding connectors Weight: 340 grams (12 ounces)
ALL MODELS						
Insertion Loss (from input to test port): 6.5 dB nominal Detector Output Polarity: Negative Output Time Constant: 2 μ S Maximum Power Input: 0.5 watts (+27 dBm) Input Connector: Type N Female except 67B and 67F Series which have BNC Female. Detector Output Connector: BNC Female						

① 46 dB directivity available as Option 1. Option 1 accuracy: $0.005 \pm 0.06\rho^2$.

② Where ρ is the reflection coefficient being measured. Accuracy includes the effects of test port reflections and directivity.

③ 75 Ω Type N Female connectors will withstand occasional mating with 50 Ω connectors without damage.

④ When used with 28A50-1 Precision Termination. The effective directivity of the bridge can be increased to 60 dB by using the Ripple Extraction return loss measurement technique with the 18A50 Air Line and 29A50-20 Offset Termination.

Table 1-3. SWR Bridges, Specifications

MODELS	FREQUENCY RANGE	DIR (dB)	ACCURACY ②	INPUT Z (ohms)	TEST PORT CONNECTOR TYPE	PHYSICAL
Series 60 SWR Bridges						
60N50 60NF50 60A50	5 MHz to 2 GHz	40 ①	$0.01 \pm 0.09\rho^2$	50	Type N Male Type N Female GPC-7	Dimensions: 6.7 x 5.1 x 2.54 cm (2-5/8 x 2 x 1 inches) excluding connectors Weight: 340 grams (12 ounces)
Series 62 SWR Bridges						
62N50 62NF50 62B50 62BF50 62N75 62NF75 62B75 62BF75 62FF75	10 to 1000 MHz	40	$0.01 \pm 0.12\rho^2$	50 50 50 50 75 75 75 75	Type N Male Type N Female BNC Male BNC Female Type N Male ③ Type N Female ③ BNC Male BNC Female Type F Female	Dimensions: 5.7 x 3.5 x 2.86 cm (2-1/4 x 1-3/8 x 1-1/8 inches) excluding connectors Weight: 170 grams (6 ounces)
Series 87 SWR Bridge						
87A50	2 to 18 GHz	35 ④	2 to 3 GHz: $0.018 \pm 0.31\rho^2$ 3 to 4 GHz: $0.018 \pm 0.2\rho^2$ 4 to 18 GHz: $0.018 \pm 0.12\rho^2$	50	GPC-7	Dimensions: 7.3 x 5.1 x 2.86 cm (2-5/8 x 2 x 1-1/8 inches) excluding connectors Weight: 340 grams (12 ounces)
Series 64 SWR Bridge						
64A50	3 to 8 GHz ⑤	36 ⑥	$0.016 \pm 0.12\rho^2$	50	GPC-7	Dimensions: 7.3 x 5.1 x 2.86 cm (2-7/8 x 2 x 1-1/8 inches) excluding connectors Weight: 284 grams (10 ounces)
Series 58A50 Comparison SWR Bridge						
58A50	2.0 to 18.0 GHz	35	2 to 3 GHz: $0.018 \pm 0.32\rho^2$ ⑦ 3 to 4 GHz: $0.018 \pm 0.2\rho^2$ 4 to 18 GHz: $0.018 \pm 0.11\rho^2$	50	GPC-7	Dimensions: 6.7 x 5.1 x 2.2 cm (2-5/8 x 2 x 7/8 inches) excluding connectors Weight: 340 grams (12 ounces)
ALL MODELS Insertion Loss (from input to test port): 6.5 dB nominal Maximum Power Input: 0.5 watts (+27 dBm) Input Connector: Type N Female, stainless steel, except 62B and 62F Series which have BNC Female.						

① Option 1 has 46 dB directivity with an accuracy of $0.005 \pm 0.09\rho^2$.

② Where ρ is the reflection coefficient being measured.

③ 75 Ω N Female connectors will withstand occasional mating with 50 Ω connectors without damage.

④ 38 dB directivity available with Option 1. Option 1 accuracy: 2 to 3 GHz: $0.011 \pm 0.31\rho^2$; 3 to 4 GHz: $0.011 \pm 0.2\rho^2$; 4 to 18 GHz: $0.011 \pm 0.11\rho^2$.

⑤ 2 to 8 GHz frequency range available as Option 2. Option 2 accuracy: 2 to 3 GHz: $0.016 \pm 0.016\rho^2$; 3 to 8 GHz: as specified above.

⑥ 42 dB directivity available as Option 1 (3 to 8 GHz). Accuracy: $0.008 \pm 0.12\rho^2$.

⑦ When used with Model 28A50-1 Termination. Accuracy is even greater when the bridge is used with an 18A50 Air Line and a 29A50-20 Offset in the Ripple Extraction return loss measurement technique.

SECTION II

THEORY OF OPERATION

2-1 INTRODUCTION

This section describes how the SWR Autotesters and bridges operate. The following discussion is intended only to acquaint the user with the measurement concept employed, and therefore does not include a mathematical analysis.

2-2 DESCRIPTION

A simplified diagram of a typical SWR bridge is shown in Figure 2-1. The SWR Autotester is identical to the bridge, except that the SWR Autotester has a built-in RF detector. The output of an RF generator is applied to the bridge circuit formed by R_a , R_b , R_c , and Z_x . Z_{det} is the input impedance of the RF detector and Z_o is the output impedance of the RF generator. Resistances R_a , R_b , and R_c are precision resistors of a value equal to the specified bridge impedance (usually 50 or 75 ohms). When the impedance of the device under test, Z_x , is exactly equal to the bridge impedance, the voltage across the RF detector is zero. This occurs because equal voltages are present across R_a , R_b , R_c , and Z_x .

When the impedance of the device under test is either higher or lower than the bridge impedance, a voltage is applied to the RF detector that is proportional to the impedance ratio of Z_x to Z_{bridge} . Since

$$SWR = \frac{Z_x}{Z_{bridge}} \quad \text{or} \quad \frac{Z_{bridge}}{Z_x}$$

(whichever is greater), the detected RF output is proportional to the SWR of the device under test.

SWR is related to other transmission line measurements such as reflection coefficient and return loss in dB, as shown in the Microwave Measurement Chart, Table 3-4.

The DC output voltage from the RF detector may be applied to a suitable test instrument such as an oscilloscope or network analyzer. If a sweep generator is used for the RF source, the oscilloscope or network analyzer displays the SWR of the device under test as a function of frequency.

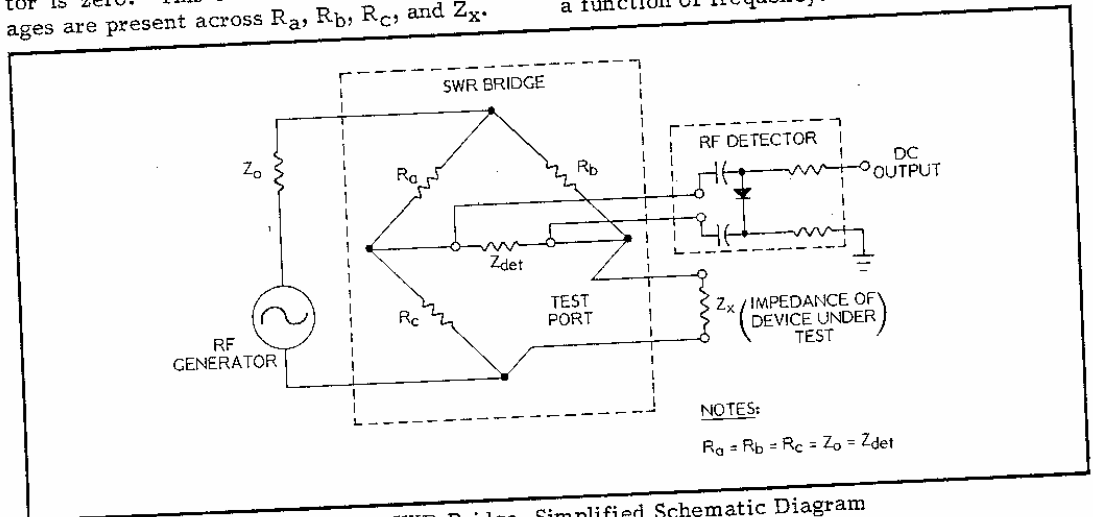

Figure 2-1. SWR Bridge, Simplified Schematic Diagram

Table 3-1. Recommended Test Equipment

INSTRUMENT	REQUIRED CHARACTERISTICS	RECOMMENDED MANUFACTURER AND MODEL NO.
Directivity Measurements Above 2 GHz		
Automated Scalar Network Analyzer	<u>Sweep Generator</u> Leveled Output ± 1.0 dB Frequency Range: 2 to 18 GHz	WILTRON 5637 with 560-10BX cable
Air Line	<u>Scalar Network Analyzer</u> Vertical Sensitivity: 0.5 dB per division Variable Offset Control	WILTRON 18 Series 19 Series
20 dB Offset	SWR: 1.002 (GPC 7 Connector) SWR: 1.006 (Type N Connector) SWR: 1.006 (WSMA Connector)	WILTRON 29 Series
Directivity Measurement Below 2 GHz		
Sweep Generator	Leveled Output ± 1.0 dB Frequency Range: 10 MHz to 2 GHz	WILTRON 6609A
Oscilloscope	Vertical Sensitivity: 10 μ V per division	Tektronix 5110 with 5A22N Differential Amplifier
Detector	SWR: 1.25	WILTRON 74 Series
Step Attenuator	0 to 50 dB in 1 dB steps	Weinschel AC- 117A-69-43
Precision Termination	<u>50 ± 0.5 Ohms</u> GPC 7 Test Port Connector Type N Test Port Connector WSMA Female Test Port Connector WSMA Male Test Port Connector	28A50-1 26N50 26S50 26SF50
	<u>75 ± 0.5 Ohms</u> Type N Test Port Connector BNC Test Port Connector	26N75 26B75
Pin Depth Measurement		
Connector Gauge	<u>GPC 7 Connector</u> Range: 0.001 to 0.250 in.	WILTRON Model 01-220
	<u>Type N Connector</u> Dial Graduations: 0.0001 in.	Model 01-224
	<u>WSMA Connector</u> Dial Graduations: 0.0001 - 0.25 in.	WILTRON 01-222

SECTION III

MAINTENANCE

3-1 INTRODUCTION

This section provides performance verification procedures and maintenance instructions. The performance of an SWR bridge is evaluated by measuring its directivity. The performance of an SWR Autotester is evaluated by measuring both directivity and waveform fidelity at the DETECTED SWR OUTPUT port. If the directivity is within specifications, and if the correct waveform patterns are observed at the output port of the SWR Autotester, the component is functioning properly.

3-2 RECOMMENDED TEST EQUIPMENT

A listing of recommended test equipment for performing directivity and pin depth measurements is provided in Table 3-1 (facing page). Equivalent test equipment items may be substituted, if the listed items are not available.

3-3 DIRECTIVITY MEASUREMENTS

Directivity measurements are frequency-limited. Above 2 GHz, a technique employing an air line is used to make a precise measurement of directivity.¹ Below 2 GHz, where the air line is not effective, an oscilloscope is used to compare the directivity of the bridge or SWR Autotester against a calibrated reference in a "Go/No-Go" method. Table 3-3 provides the procedure for measuring directivity using an air line. Table 3-5 provides the procedure for the Go/No-Go method.

Measuring the directivity of the 97S50 and 97SF50 SWR Autotesters above 2 GHz requires using a 19SF50 or 19S50 Air Line,

respectively. The WSMA connectors on the SWR Autotesters and air lines have been designed for mating with SMA connectors. When two WSMA connectors are mated, they require a washer for pin-depth compensation of the center conductors. The only exceptions are the WSMA open/short and the sweep generator RF OUTPUT connector, they have been optimized for use with WSMA. An envelope containing six or more of these washers has been packaged with each air line. Table 3-2 provides instructions for installing these washers. The photographs show washers being installed in the 560-98S50 and -98SF50 SWR Autotesters. Washers are installed the same way in the 97S50 and 97SF50. Before starting the procedure in Table 3-2, perform the following steps:

- a. Press the POWER pushbutton on the 560A and 6637A. Set the 560A controls as shown in Figure 3-1.
- b. On the 6637A:
 1. Press RESET.
 2. Press F1-F2.
 3. Press F1 and set for 2 GHz.
- c. On the 560A:
 1. Press REF POS LOCATE and adjust the SET potentiometer to position the reference trace on the center graticule line; release REF POS LOCATE.
 2. Adjust OFFSET for a 00.0 reading on the OFFSET dB display.
 3. Adjust ZERO dB SET to position the

¹Error Averaging is the technique used. This technique is described in WILTRON Technical Review #8, "An Easy-to-Use Method for Measuring Small SWRs to Better Than Computer-Aided Accuracy Levels."

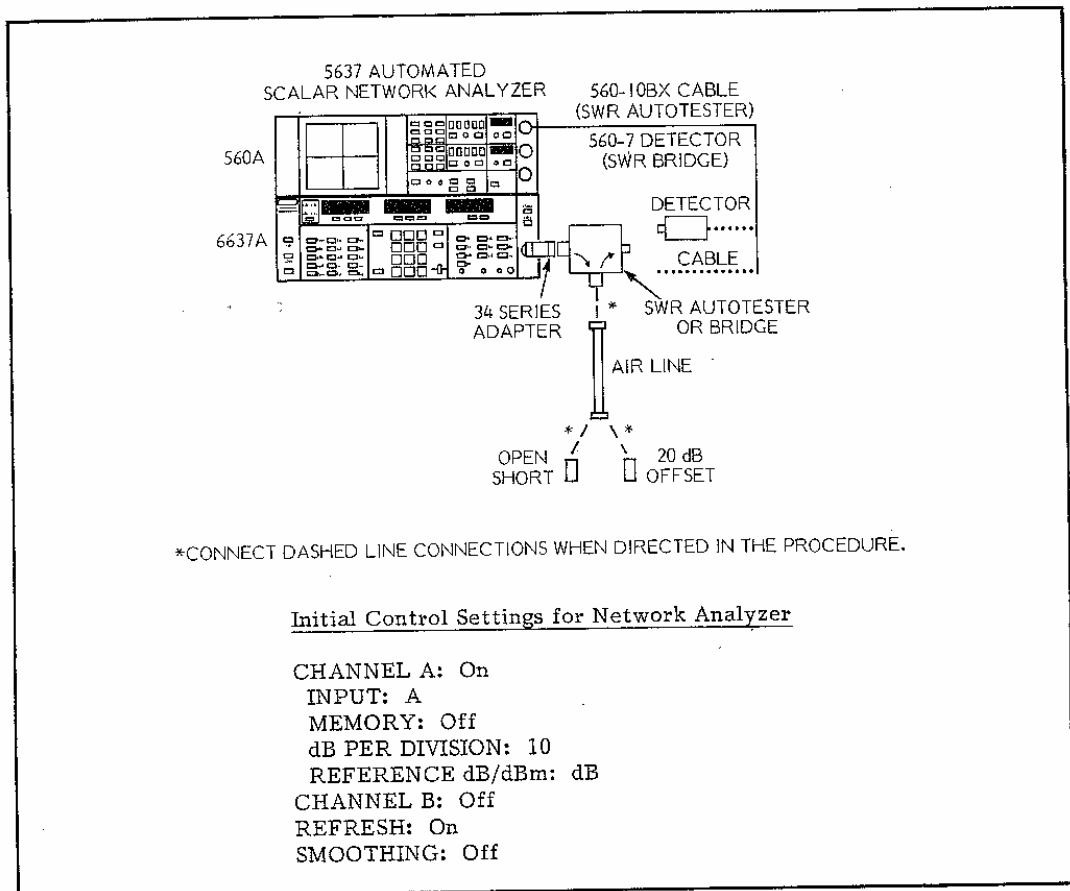

Figure 3-1. Test Setup for Measuring Directivity Above 2 GHz

- trace on the center graticule line.
4. Press dB PER DIVISION 1.
 5. Proceed to Table 3-2.

3-4 PIN DEPTH MEASUREMENTS

The following procedure provides instructions for measuring the pin depth of GPC and type N male and female connectors. Instructions for measuring pin depth on WSMA connectors are given in the instruction sheet for the Model 01-160 Gauging Set.

Pin-depth is a critical specification for

connectors, both those installed on SWR Autotesters and Bridges and those that mate with them.

CAUTION

Measure the pin depth on mating connectors prior to their connection to the test port on SWR Bridges and Autotesters. Ensure that the pin depth on such connectors does not exceed the +0.000 specification for the GPC-7 and type-N female connectors, or the -0.003 MMC Gauge reading for the type-N male connectors.

a. GPC 7 Connectors

1. Calibrate the gauge for zero, as follows:
 - (a) Press the gauge against the calibrated gauge block.
 - (b) Loosen the knurled knob and turn the serrated ring until the "0" on the dial aligns with the pointer. Tighten the knob.
2. Press the measurement plane of the gauge against the center conductor on the connector to be measured.
3. Read the pin depth setting.
4. If the setting is out of tolerance, the bridge or SWR Autotester should be returned to WILTRON for repair.

b. Type N-Male Connectors

1. Install the adapter stamped "N" over the gauge plunger mechanism. M"
2. Calibrate the gauge for zero, as follows:
 - (a) Insert the measuring plunger into the sleeve in the "M" half of the calibration device.
 - (b) Loosen the knurled knob and turn the serrated ring until the "0" aligns with the pointer.
3. Install the measuring plunger over the center pin on the connector to be measured.
4. Read the pin depth setting.
5. If the setting is out of tolerance, the bridge or SWR Autotester should be returned to WILTRON for repair.

c. Type N-Female Connectors

1. Install the adapter stamped "N" over the gauge plunger mechanism. F"

2. Calibrate the gauge for zero, as follows:

- (a) Insert the protrusion on the "F" half of the calibration device into the sleeve on the gauge adapter.
- (b) Loosen the knurled knob and turn the serrated ring until the "0" aligns with the pointer.

3. Install the measuring plunger over the center pin on the connector to be measured.
4. Read the pin depth setting.
5. If the setting is out of tolerance, the bridge or SWR Autotester should be returned to WILTRON for repair.

3-5 MAINTENANCE

3-5.1 Adjustments

WILTRON recommends that no adjustments or maintenance other than cleaning be attempted by the customer. The instrument should be returned to WILTRON for repair and/or service when needed.

3-5.2 Cleaning

Connector interfaces - especially the outer conductors on the GPC-7 and SMA connectors - should be kept clean and free of dirt and other debris. Alcohol is the recommended cleaning agent, and a clean, damp cotton swab is the recommended applicator.

CAUTION

On some models of SWR Autotesters and bridges, the test port connector has small teflon washer located on the center conductor (paragraph 1-4d). DO NOT DISTURB THIS WASHER. Any movement will degrade the instrument's directivity.

Table 3-2. Washer Installation and Component Mating Procedure

1. Separate a washer, and trim away the ears.

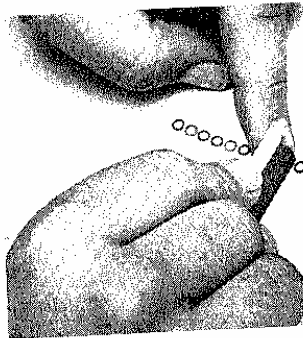

**97SF50 SWR AUTOTESTER
WITH 19S50 AIR LINE**

2. Connect the SWR Autotester to the sweep generator (test port up).



OR

**97S50 SWR AUTOTESTER
WITH 19SF50 AIR LINE**

2. Connect the SWR Autotester to the sweep generator (test port down).

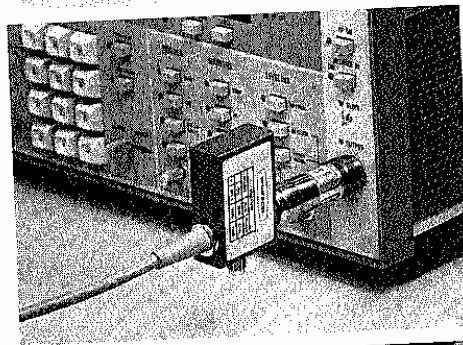

3. Connect the open end of the open/short to the beaded end of the air line.



Table 3-2. Washer Installation and Component Mating Procedure (Continued)

**97SF50 SWR AUTOTESTER
WITH 19S50 AIR LINE**

4. Insert the washer into the opening of the SWR Autotester test port connector.

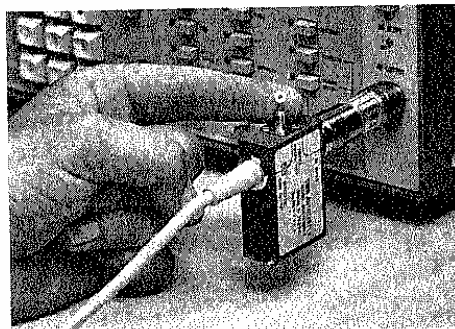

OR

**97S50 SWR AUTOTESTER
WITH 19SF50 AIR LINE**

Insert the washer into the beadless end of the air line.

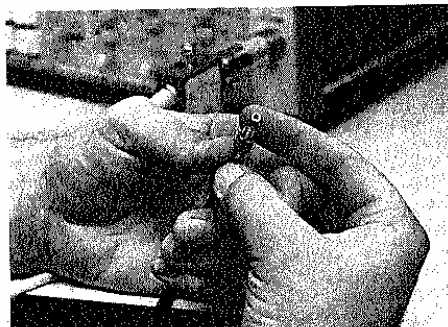

5. • Tilt the air line horizontally.
• Align the center conductor with the center of the connector opening.

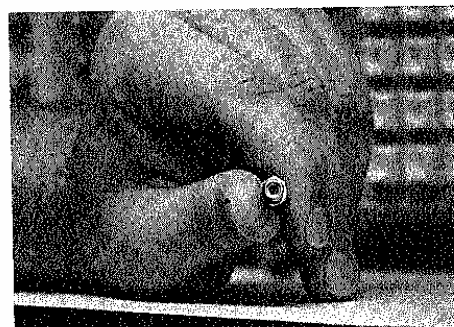

6. • Loosen the RF INPUT connection and rotate the SWR Autotester as shown.
• Align the test port with the air line.
• Carefully mate the two connectors.

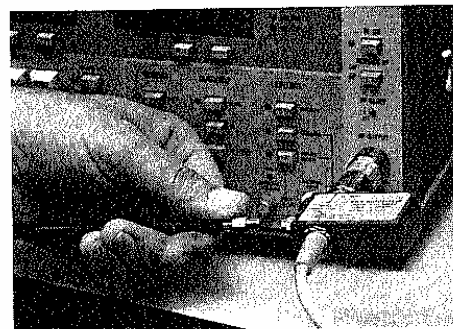
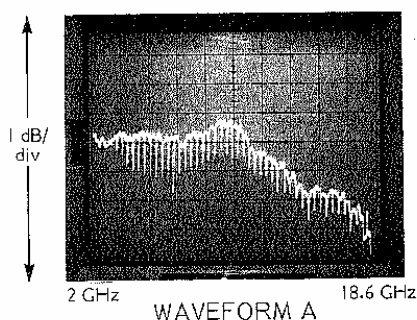

Table 3-2. Washer Installation and Component Mating Procedure (Continued)

NOTE

Orienting the air line horizontally usually makes it easier to effect a good connection (it is easier to determine when the center conductor is centered in the connector opening). It is not the only way, however. A good connection may also be obtained when the air line is oriented vertically.

7. While observing the network analyzer display, begin by slowly tightening the connector coupling. While tightening,
- if Waveform A appears, STOP. The sharp spikes in the waveform indicate improper contact with the center conductor has been made. Uncouple the connectors, examine the washer for damage, and repeat steps 5 thru 7.
 - if Waveform B appears, a good connection has been made. Continue tightening the coupling, but DO NOT OVER-TORQUE. Finger-tight is sufficient.



Bad center-pin mating between air line and SWR Autotester

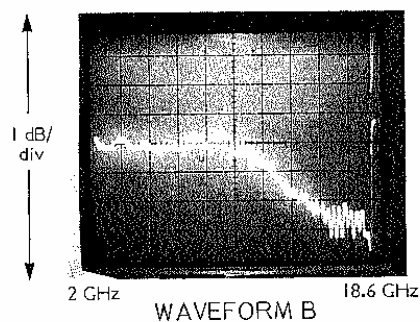

Good center-pin mating between air line and SWR Autotester

8. Rotate the SWR Autotester clockwise, until the air line is vertical; tighten the RF INPUT connection.
9. Separate another washer (step 1) and install it in the Model 29S50-20 or 29SF50-20 20 dB offset.
10. Proceed with the directivity measurements in Table 3-3, beginning with step 7.

Table 3-3. Procedure for Measuring Directivity Above 2 GHz

1. Connect the test equipment as shown in Figure 3-1.
2. Press POWER on both instruments and set the 560A controls to their initial settings.
3. On the 6637A,
 - a. Press RESET.
 - b. Press F1-F2.
 - c. Press F1 and set for 2 GHz.
 - d. Press F2 and set for 18 GHz.
4. On the 560A,
 - a. Press REF POS LOCATE and adjust the SET potentiometer to position the reference trace on the center graticule line; release REF POS LOCATE.
 - b. Adjust OFFSET for a 00.0 reading on the OFFSET dB display.
 - c. Adjust ZERO dB SET to position the trace on the center graticule line.
5. Connect the Open to the beaded end of the air line.
6. Connect the beadless end of the air line to the test port, as shown in Figure 3-1. If, after tightening the air line connector, the 560A trace has spikes like those shown in Waveform A, below, the center conductor is not making a good connection. Disconnect the air line, remate the center conductor, and retighten the connector. Waveform B, below, indicates a good connection.

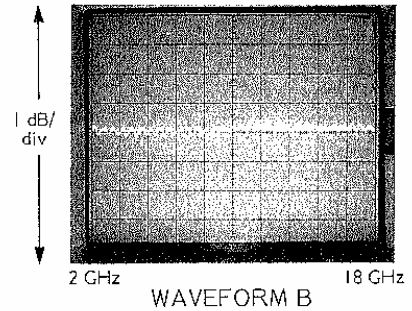

7. On the 560A,
 - a. Press dB PER DIVISON .2.
 - b. Press STORE TRACE. The display should resemble Waveform C, below.

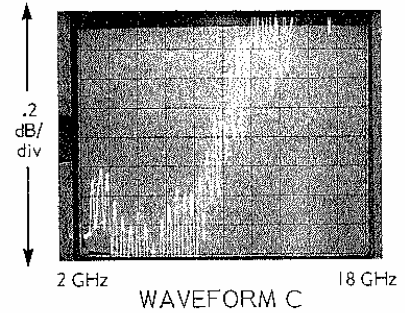

8. Remove the Open and install the Short.
9. On the 560A, sequentially press MEMORY AVG, STORE TRACE, and SUBTRACT. The trace should resemble Waveform D, below.

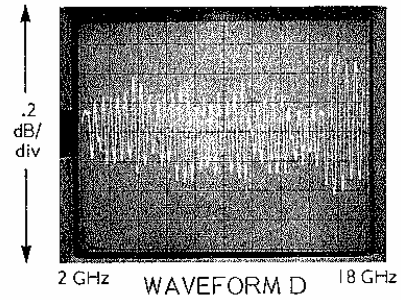
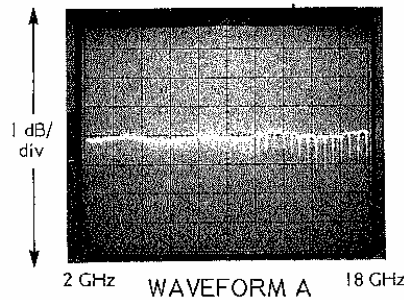

Table 3-3. Procedure for Measuring Directivity Above 2 GHz (Continued)

10. Remove the Short and install the 20 dB Offset.

NOTE

For the 97S50 and 97SF50 Air Lines: After the open and short have been averaged and the 20 dB offset has been attached, slightly loosening and retightening the connections between the test port and air line may improve center-conductor mating, thereby resulting in a lower-amplitude peak-to-peak ripple pattern (higher directivity).

d. The display should resemble Waveform E, below.

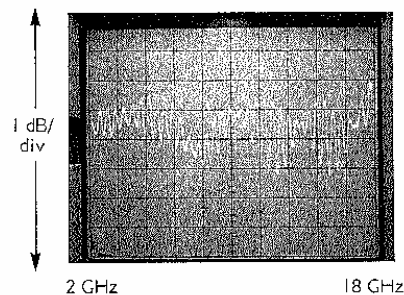

WAVEFORM E

11. On the 560A,

- a. Press dB PER DIVISION 1.
- b. Adjust OFFSET to position the trace near center screen. The OFFSET dB display should read approximately -20.0.
- c. Select the ripple with the greatest peak-to-peak value and position its average point (see NOTE) on the center graticule line.

NOTE

The average point is approximately halfway between the peak and trough values for ripples 3 dB or less. For ripples greater than 3 dB, refer to Table 3-4 to find the average value.

e. Note the OFFSET dB display. This is the value of the 20 dB Offset.

f. Measure the peak-to-peak value of the selected ripple.

12. Refer to the RF Measurement Chart in Table 3-4 for the following steps:

- a. In the "REF ±x, Peak to Peak Ripple, dB," column, find the value nearest to the peak-to-peak signal value measured in step 9f.
- b. Read the coordinate value from the "x dB Below Reference" column.
- c. Add the dB value from step b., above, to the OFFSET dB value measured in step 9e. This sum is the SWR Autotester's or bridge's worst-case directivity. It should equal or exceed the specification in Table 1-2 or 1-3.

Table 3-4. Microwave Measurement Chart

Conversion tables for Return Loss, Reflection Coefficient, and SWR with tabular values for interactions of a small phasor x with a large phasor (unity reference) expressed in dB related to reference.

SWR	REFLECTION COEFFICIENT	RETURN LOSS dB	RELATIVE TO UNITY REFERENCE			
			X dB BELOW REFERENCE	REF + X dB	REF - X dB	REF ± X PEAK TO PEAK RIPPLE dB
17.3910	.8913	1	1	5.5350	-19.2715	24.8065
8.7242	.7943	2	2	5.0780	-13.7365	18.8145
5.8480	.7079	3	3	4.6495	-10.6907	15.3402
4.4194	.6310	4	4	4.2489	-8.6585	12.9073
3.5698	.5623	5	5	3.8755	-7.1773	11.0528
3.0095	.5012	6	6	3.5287	-6.0412	9.5699
2.6146	.4467	7	7	3.2075	-5.1405	8.3480
2.3229	.3981	8	8	2.9108	-4.4096	7.3204
2.0999	.3548	9	9	2.6376	-3.8063	6.4439
1.9250	.3162	10	10	2.3866	-3.3018	5.6884
1.7849	.2818	11	11	2.1567	-2.8756	5.0322
1.6709	.2512	12	12	1.9465	-2.5126	4.4690
1.5769	.2239	13	13	1.7547	-2.2013	3.9861
1.4935	.1995	14	14	1.5802	-1.9331	3.5133
1.4326	.1778	15	15	1.4216	-1.7007	3.1224
1.3767	.1585	16	16	1.2778	-1.4988	2.7766
1.3290	.1413	17	17	1.1476	-1.3227	2.4703
1.2880	.1259	18	18	1.0299	-1.1687	2.1986
1.2528	.1122	19	19	.9237	-1.0337	1.9574
1.2222	.1000	20	20	.8279	-.9151	1.7430
1.1957	.0891	21	21	.7416	-.8108	1.5524
1.1726	.0794	22	22	.6639	-.7189	1.3828
1.1524	.0708	23	23	.5941	-.6378	1.2319
1.1347	.0631	24	24	.5314	-.5661	1.0975
1.1192	.0562	25	25	.4752	-.5027	.9779
1.1055	.0501	26	26	.4248	-.4466	.8714
1.0935	.0447	27	27	.3796	-.3969	.7765
1.0829	.0398	28	28	.3391	-.3529	.6919
1.0736	.0355	29	29	.3028	-.3138	.6166
1.0653	.0316	30	30	.2704	-.2791	.5495
1.0580	.0282	31	31	.2414	-.2483	.4897
1.0515	.0251	32	32	.2155	-.2210	.4365
1.0458	.0224	33	33	.1923	-.1967	.3890
1.0407	.0200	34	34	.1716	-.1751	.3467
1.0362	.0178	35	35	.1531	-.1558	.3090
1.0322	.0158	36	36	.1366	-.1388	.2753
1.0287	.0141	37	37	.1218	-.1236	.2454
1.0255	.0126	38	38	.1087	-.1100	.2187
1.0227	.0112	39	39	.0969	-.0980	.1949
1.0202	.0100	40	40	.0864	-.0873	.1737
1.0180	.0089	41	41	.0771	-.0778	.1548
1.0160	.0079	42	42	.0687	-.0693	.1380
1.0143	.0071	43	43	.0613	-.0617	.1230
1.0127	.0063	44	44	.0546	-.0550	.1096
1.0113	.0056	45	45	.0487	-.0490	.0977
1.0101	.0050	46	46	.0434	-.0436	.0871
1.0090	.0045	47	47	.0387	-.0389	.0776
1.0080	.0040	48	48	.0345	-.0346	.0692
1.0071	.0035	49	49	.0308	-.0309	.0616
1.0063	.0032	50	50	.0274	-.0275	.0549
1.0057	.0028	51	51	.0244	-.0245	.0490
1.0050	.0025	52	52	.0218	-.0218	.0436
1.0045	.0022	53	53	.0194	-.0195	.0389
1.0040	.0020	54	54	.0173	-.0173	.0347
1.0036	.0018	55	55	.0154	-.0155	.0309
1.0032	.0016	56	56	.0138	-.0138	.0275
1.0028	.0014	57	57	.0123	-.0123	.0245
1.0025	.0013	58	58	.0109	-.0109	.0219
1.0022	.0011	59	59	.0097	-.0098	.0195
1.0020	.0010	60	60	.0087	-.0087	.0174

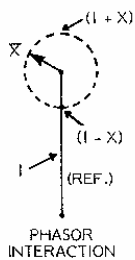

Table 3-5. Direct, Go/No-Go Method of Measuring Directivity

1. Set up the equipment as shown in Figure 3-2. Position the oscilloscope and step attenuator controls as shown. Do not connect the termination to the test port.
2. On the 6609A, press RESET. (Frequency sweep: .01 to 2 GHz.)
3. On the step attenuator, position the control to a dB setting equal to the SWR Autotester or bridge directivity, as specified in Table 1-2 or 1-3.
4. On the oscilloscope, adjust the vertical controls to position the frequency plot (see below) on a convenient reference line.
5. Connect the termination to the test port of the SWR Autotester or bridge.
6. On the step attenuator, set the control to 0 dB.
7. Observe the oscilloscope display. If the measured directivity signal is above the reference line, the directivity exceeds that specified in Table 1-2 or 1-3.

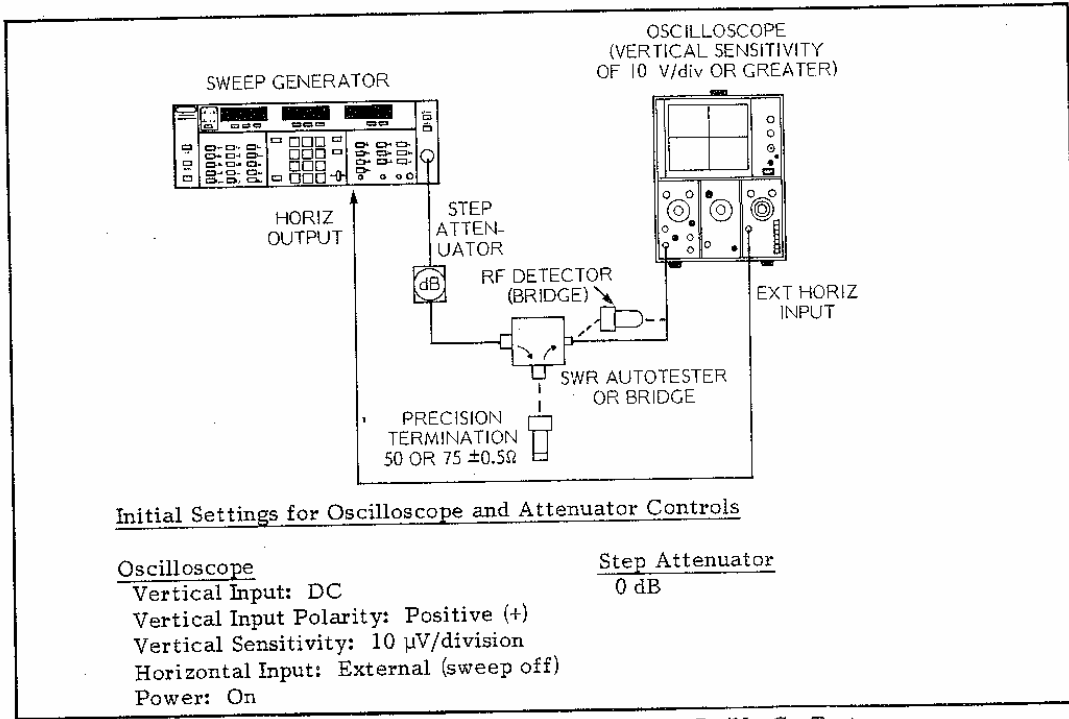
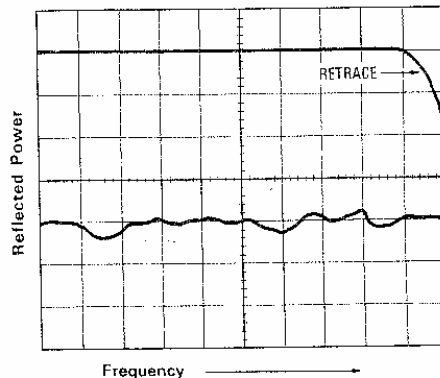

Figure 3-2. Equipment Setup for Direct, Go/No-Go Test